

THIS DOCUMENT IS THE PROPERTY OF
KEYSTONE ELECTRONICS CORP. AND
SHALL NOT BE REPRODUCED, DISTRIBUTED
OR USED AS A BASIS FOR MANUFACTURE
WITHOUT PRIOR WRITTEN PERMISSION
FROM KEYSTONE ELECTRONICS CORP.

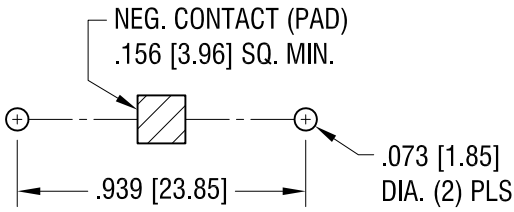

MOUNTING DETAIL

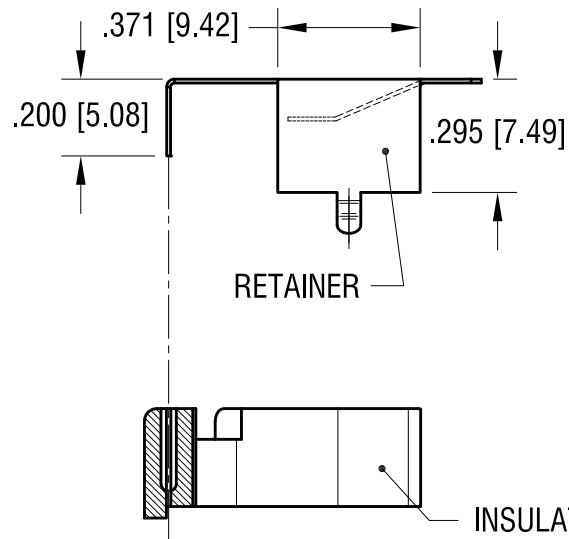
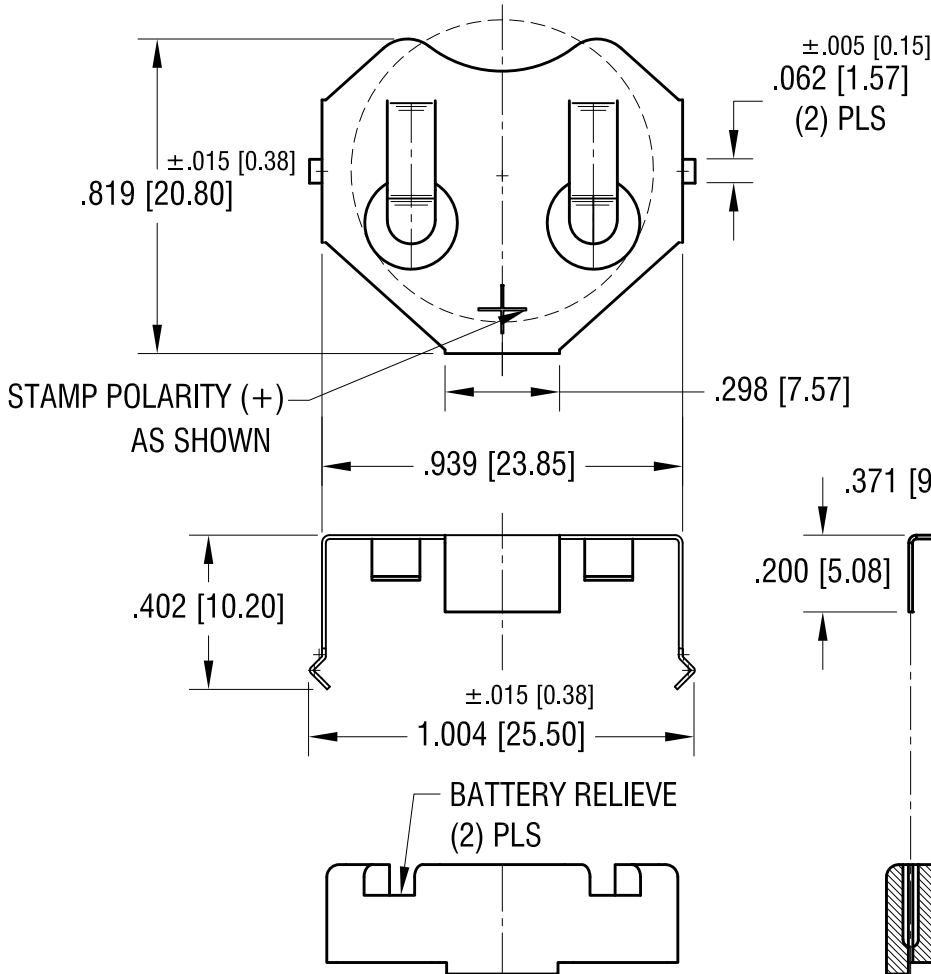
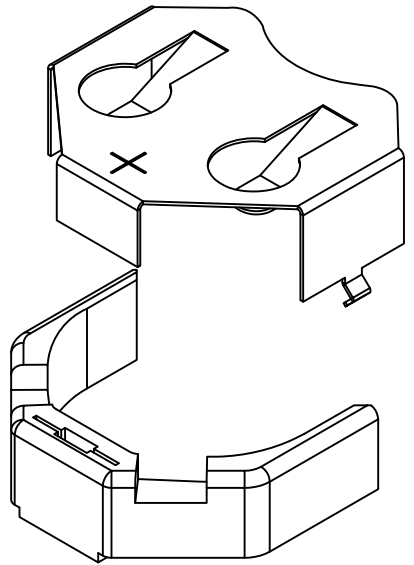

NOTE:

1. CLIP MAT'L: .010 TH'K FULL HARD PHOSPHOR BRONZE
INSULATOR MAT'L: HIGH TEMPERATURE NYLON, UL 94V-0
2. CLIP FINISH: TIN NICKEL PLATE
3. PARTS SUPPLIED UNASSEMBLED

KEYSTONE ELECTRONICS CORP.

www.keyelco.com • ASTORIA, N.Y. 11105-2017 • Tel (718) 956-8900

PART NAME			
THM COIN CELL CLIP FOR TWO 2032			
MATERIAL			
AS NOTED			
FINISH		DRN BY	DATE
AS NOTED		NT	4.21.11
		APP'D	SCALE
		LN	2X
TOLERANCES	INCH [MM]	CODE	DWG NO.
DECIMAL	$\pm .010$ [± 0.25]	C	3025-2
ANGULAR	$\pm 1^\circ$		
UNLESS OTHERWISE SPECIFIED			

DATE	DESCRIPTION	REV.