

**Impact™  
Daughtercard  
Removal Tool**

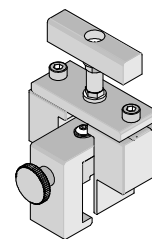

**Application Tooling  
Specification Sheet**



**Order No. 62100-8070**

**FEATURES**

- This tool is designed for the removal of an Impact™ Daughtercard signal module from a PCB
- This tool will not remove the Impact™ right-angle-male (RAM) signal module (use tool 62202-4350)
- Use tool 622018735 for inserting 5 pair by 12 column Daughtercard assemblies

**SCOPE**

Products: Impact™ Daughtercard signal module, 5 Pair x 12 columns. See Product List below for order numbers.

**Product List**

The following is a partial list of the product order numbers and their specifications this tool is designed to run. Updates to this list are available on [www.molex.com](http://www.molex.com).

Series No.	Guide Style	Columns	5 Pair Assembly Order Number							
76060	Open	12	76060-0012	76060-1012	76060-0022	76060-1022				
	Left	12	76060-2012	76060-2022	76060-2052	76060-2062	76060-2112	76060-2122		
			76060-2152	76060-2162	76060-2212	76060-2222	76060-2252	76060-2262		
			76060-2312	76060-2322	76060-2352	76060-2362	76060-2412	76060-2422		
			76060-2452	76060-2462	76060-2512	76060-2522	76060-2552	76060-2562		
			76060-2612	76060-2622	76060-2652	76060-2662	76060-2712	76060-2722		
			76060-2752	76060-2762	76060-2812	76060-2822	76060-2852	76060-2862		
			76060-3012	76060-3022	76060-3052	76060-3062	76060-3112	76060-3122		
			76060-3152	76060-3162	76060-3212	76060-3222	76060-3252	76060-3262		
			76060-3312	76060-3322	76060-3352	76060-3362	76060-3412	76060-3422		
			76060-3452	76060-3462	76060-3512	76060-3522	76060-3552	76060-3562		
			76060-3612	76060-3622	76060-3652	76060-3662	76060-3712	76060-3722		
			76060-3752	76060-3762	76060-3812	76060-3822	76060-3852	76060-3862		
			76060-9001							
			Right	12	76060-4012	76060-4022	76060-4052	76060-4062	76060-4112	76060-4122
					76060-4152	76060-4162	76060-4212	76060-4222	76060-4252	76060-4262
					76060-4312	76060-4322	76060-4352	76060-4362	76060-4412	76060-4422
	76060-4452	76060-4462			76060-4512	76060-4522	76060-4552	76060-4562		
	76060-4612	76060-4622			76060-4652	76060-4662	76060-4712	76060-4722		
	76060-4752	76060-4762			76060-4812	76060-4822	76060-4852	76060-4862		
	76060-5012	76060-5022			76060-5052	76060-5062	76060-5112	76060-5122		
	76060-5152	76060-5162			76060-5212	76060-5222	76060-5252	76060-5262		
	76060-5312	76060-5322			76060-5352	76060-5362	76060-5412	76060-5422		
	76060-5452	76060-5462			76060-5512	76060-5522	76060-5552	76060-5562		
	76060-5612	76060-5622			76060-5652	76060-5662	76060-5712	76060-5722		
	76060-5752	76060-5762			76060-5812	76060-5822	76060-5852	76060-5862		
	76060-9002									

## DESCRIPTION

Figure 1 illustrates the principal parts of the removal tool.

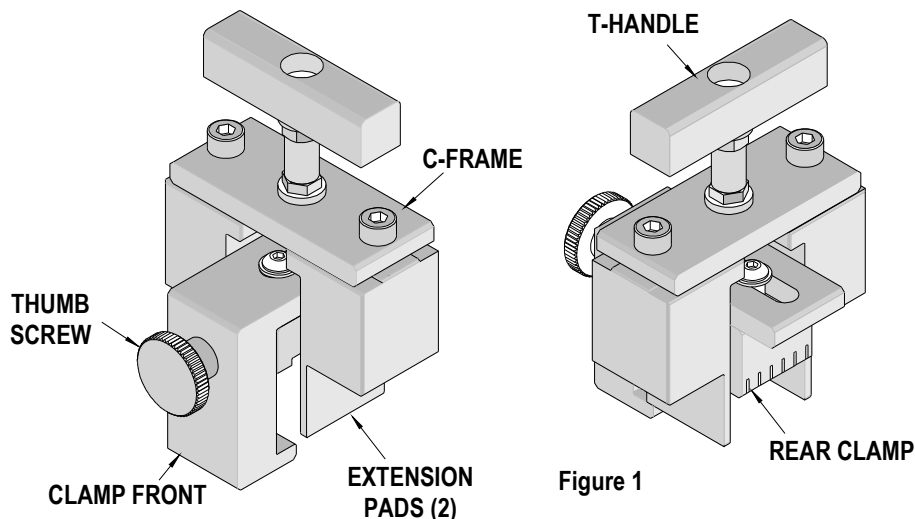

Figure 1

## Tool Restrictions

These tools require a "Keep Out Zone" on the open side of the Daughtercard free of components. The right and left sides should be 3mm (.12"). See Figure 2. This is a general requirement, regardless of the module being removed.

**Note:** Be sure that all parts of the removal tool will clear any components on the printed circuit board during use. Tape may also be placed over circuit traces or on the bottom of the Extension Pads for added protection of the printed circuit board.

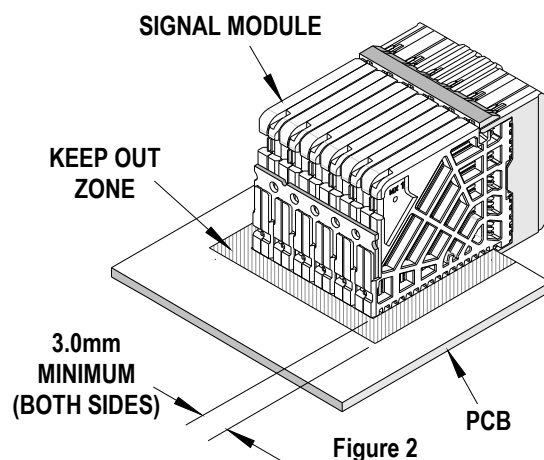

Figure 2

## Tool Operation

1. Turn the T-handle counter clockwise until the clamp assembly is free of the upper frame.
2. Turn the thumb screw counter clockwise so the clamp front can open to fit over the Daughtercard shroud. See Figure 3.
3. Position the rear clamp so it is flush with the side of the outer wafer. The "teeth" of the rear clamp should fit snugly in the cut-outs of the wafers. See Figure 4.
4. Turn the thumb screw clockwise to close the clamp tightly against the Daughtercard.
5. Position the tool frame over the closed clamp and turn the T-handle clockwise until the Extension Pads contact the PCB surface. See figure 5.
6. Continue turning the T-handle clockwise until the Daughtercard is free from the PCB.
7. Move the extraction tool away from the PCB. Turn the thumb screw counterclockwise to open the clamp and Daughtercard from the extractor tool. Discard the Daughtercard module.

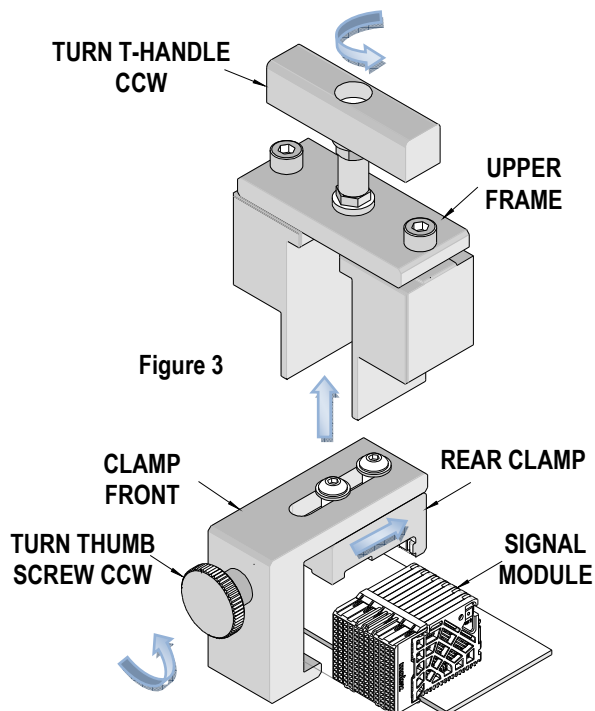
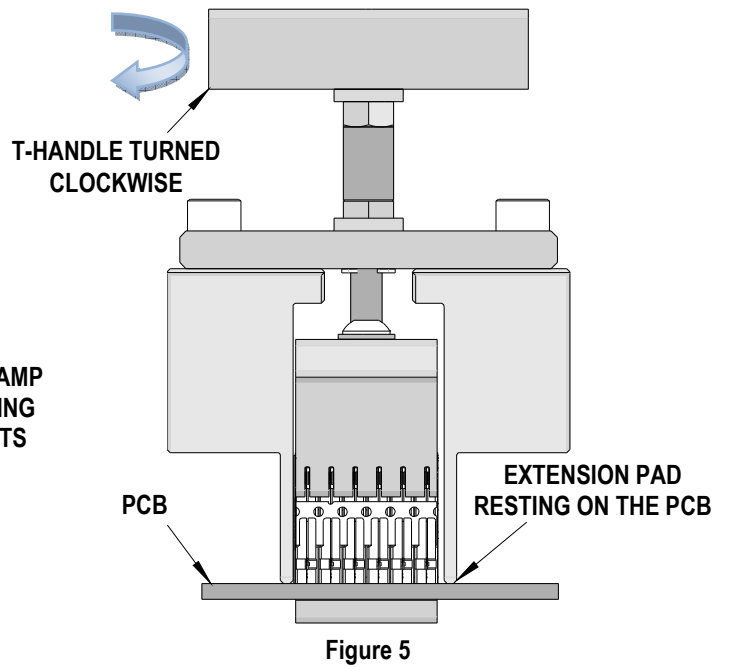
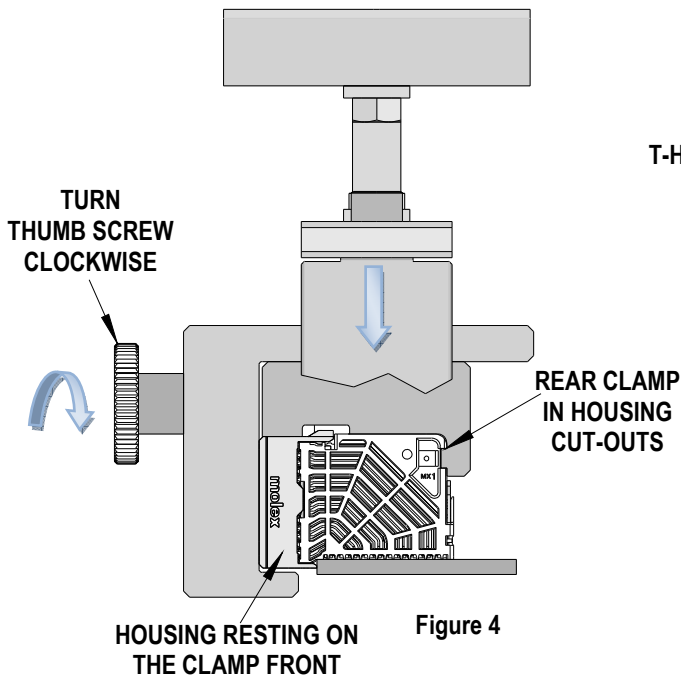

Figure 3



### Daughtercard Module Assembly Removal (When mounted alongside other Daughtercard)

When Daughtercard modules are stacked end to end on one side the extractor tool can be adjusted to allow the removal of the desired Daughtercard module.

1. Remove the M5 x 10 long SHCS on the side where the extra module is located. See Figure 6.
2. Rotate the Extension Pad 180°.
3. Reinstall the Extension Pad with the M5 x 10 long SHCS.
4. Follow the Tool Operation procedure for Daughtercard removal.

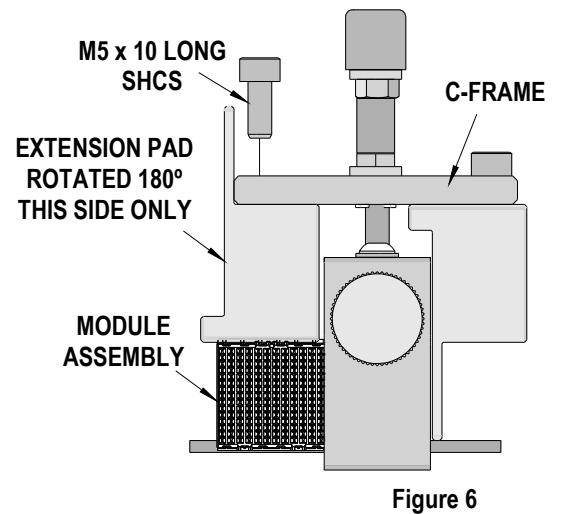

### Daughtercard Module Assembly Removal (With Daughtercard assemblies on both sides)

When Daughtercard modules are stacked end to end on both sides, the extractor tool can be adjusted to allow the removal of the middle Daughtercard module.

1. Remove the M5 x 14 long SHCS on each the side where the extra modules are located. See Figure 7.
2. Rotate the Extension Pads 180°.
3. Reinstall the Extension Pads with the M5 x 10 long SHCS.
4. Follow the Tool Operation procedure for Daughtercard removal.

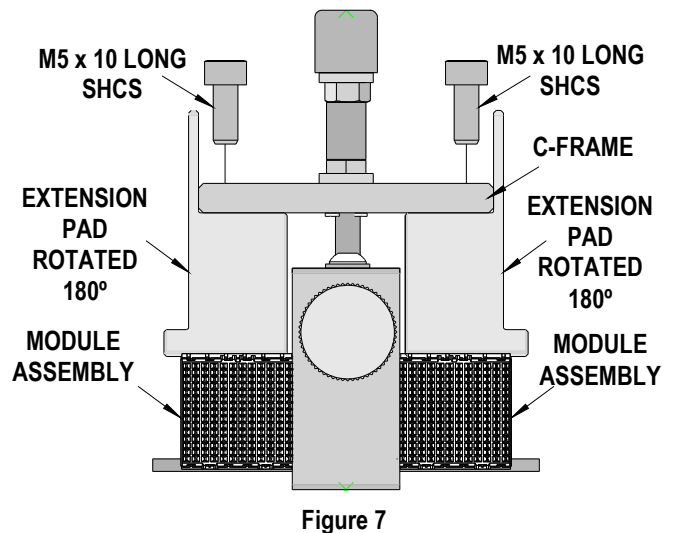

## Daughtercard with Guide Module Assembly Removal

When removing a Daughtercard with a Guide module the extractor tool can be adjusted for the additional space of the guide module.

1. Remove the M5 x 10 long SHCS on the side where the guide module is located.
2. Move the Extension Pad out on this side. See Figure 8.
3. Align the second threaded hole in the extension pad with the C-frame.
4. Reinstall the M5 x 10 long SHCS thru the C-frame.

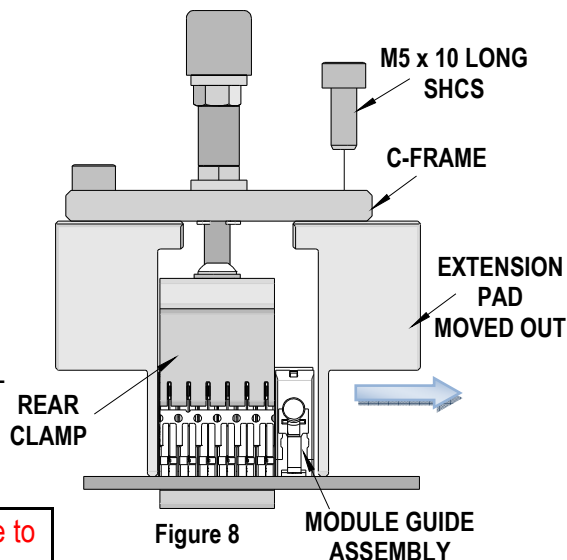

**NOTE:** Remember to remove the screw holding the guide module to the PCB before removing the Daughtercard module.

5. Follow the Tool Operation procedure for Daughtercard removal.

## Maintenance

It is recommended that each operator of the tool be made aware of, and responsible for, the following maintenance steps:

1. Remove dust, moisture, and other contaminants with a clean brush, or soft, lint free cloth.
2. Do not use any abrasive materials that could damage the tool.
3. Make certain all pins; pivot points and bearing surfaces are protected with a thin coat of high quality machine oil. Do not oil excessively.
4. When tool is not in use, store in a clean, dry area.

**CAUTION:** Molex specifications are valid only when used with Molex terminals, applicators and tooling.

## Contact Information

For more information on Molex application tooling please contact Molex at 1-800-786-6539.

Visit our Web site at <http://www.molex.com>