

LOC GT	DIST -	REVISIONS				
P	LTR	DESCRIPTION	DATE	DWN	APVD	
	A2	SEE ECR-12-005245	20MAR12	MP	VC	

**WIRE BARREL**

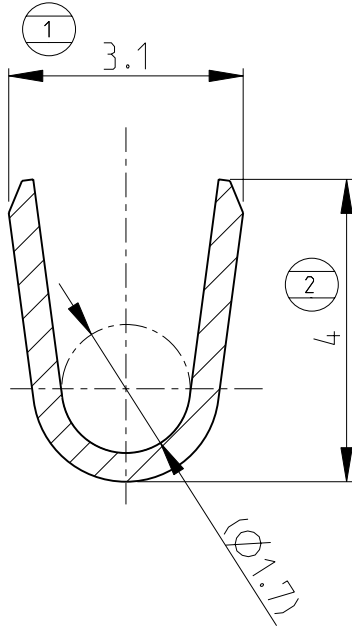

**INSULATION BARREL**

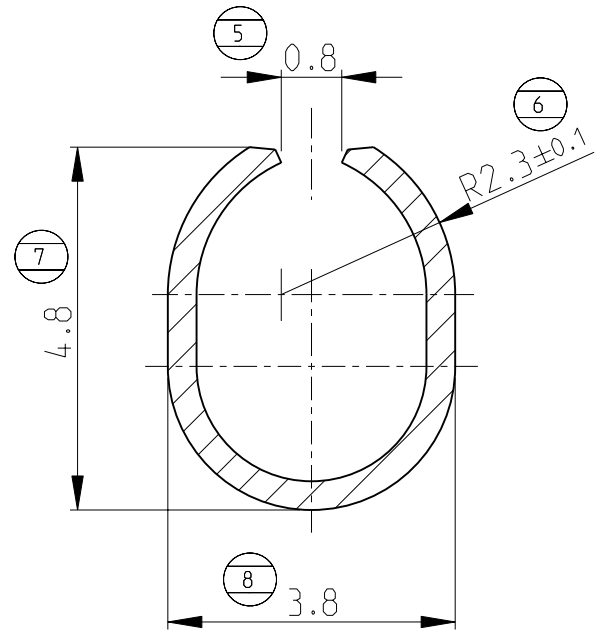

NOTES:

- 1 MISSING DIMENSIONS SEE DRAWING OF STRIP FORM PN 964133
- 2 CUT OFF TAB MAX. 0.5mm
- 3 FOR USE WITH CRIMP HANDTOOL PN 539635-1 WITH CRIMPING HEAD PN 539734-2
- 4 CRIMP PRE-FORMED

0-964133-4	SEL. GOLD PLATED	CuSn4	0-964142-4	FOR CURRENT REVISION SEE STRIP-DRAW.
0-964133-3	PRETINNED	CuNiSi	0-964142-3	
0-964133-2	PRETINNED	CuSn4	0-964142-2	
0-964133-1	PLAIN	CuSn4	0-964142-1	
<b>MADE FROM (STRIP)</b>	<b>FINISH</b>	<b>MATERIAL</b>	<b>LP NO</b>	<b>REV</b>

DIMENSIONS: mm	DWN M. Pavlicek	26MAR2012	MATERIAL	SEE TABLE	FINISH	-
	CHK M. Benes	27MAR2012	TE Connectivity			
TOLERANCES UNLESS OTHERWISE SPECIFIED:	APVD V. Cech	28MAR2012				
0 PLC ± 1 PLC ± ±0,3 2 PLC ± 3 PLC ± 4 PLC ± ANGLES ±2°	PRODUCT SPEC	-	SIZE	CAGE CODE	DRAWING NO	RESTRICTED TO
	APPLICATION SPEC	114-18014	A 4	00779	©-964142	-
	WEIGHT	-	CUSTOMER DRAWING		SCALE	10:1
			SHEET	1	OF	1
			REV	A2		