

TWR-K60F120M Tower Module

User's Manual

Rev 1.0

Table of Contents

1	TWR-K60F120M and TWR-K60F120M-KIT Overview	4
1.1	Contents	5
1.2	Features	5
1.3	Getting Started	6
1.4	Reference Documents	6
2	Hardware Description	7
2.1	K60FN1M0 Microcontroller	7
2.2	Clocking	8
2.3	System Power	9
2.3.1	RTC VBAT	9
2.4	Debug Interface	9
2.4.1	OSJTAG	9
2.4.2	Cortex Debug+ETM Connector	9
2.5	NAND Flash	10
2.6	Infrared Port	10
2.7	Accelerometer	10
2.8	Potentiometer, Pushbuttons, LEDs	10
2.9	General Purpose Tower Plug-in (TWRPI) Socket	11
2.10	Touch Interface	11
2.11	Ethernet	12
2.12	USB	13
2.12.1	FS/LS USB	13
2.12.2	HS USB	13
2.13	Secure Digital Card Slot	13
2.14	External Bus Interface – FlexBus	13
3	Jumper Table	14
4	Input/Output Connectors and Pin Usage Table	15
5	Tower Elevator Connections	17

List of Figures

Figure 1. Freescale Tower System Overview 4
 Figure 2. Callouts on front side of the TWR-K60F120M 6
 Figure 3. Callouts on back side of the TWR-K60F120M 6
 Figure 4. TWR-K60F120M Block Diagram 7

List of Tables

Table 1. Cortex Debug+ETM Connector Pinout 9
 Table 2. General Purpose TWRPI socket pinout 11
 Table 3. Touch TWRPI socket pinout 12
 Table 4. Ethernet operation jumper settings 12
 Table 5. TWR-K60F120M Jumper Table 14
 Table 6. I/O Connectors and Pin Usage Table 15
 Table 7. TWR-K60F120M Primary Connector Pinout 17
 Table 8. TWR-K60F120M Secondary Connector Pinout 20

Revision History

Revision	Date	Changes
0.1	Dec 13, 2011	Initial Release for PWA 700-27167 Rev B
1.0	Nov 20, 2012	Added information on running EVB at 150MHz Added jumper details for rev C board Added information on using trace

1 TWR-K60F120M and TWR-K60F120M-KIT Overview

The TWR-K60F120M is a development board for the K10, K20 and K60 family 32-bit ARM® Cortex™-M4 MCUs. The TWR-K60F120M is populated with a device rated for 120 MHz operation across the full -40C to 85C temperature range. At room temperatures the board can be over-clocked to 150 MHz to allow for evaluation of the K10, K20, and K60 devices that are rated for 150 MHz operation across the full temperature range.

The TWR-K60F120M is a Tower Controller Module compatible with the Freescale Tower System. It can function as a stand-alone, low-cost platform for the evaluation of the Kinetis K10, K20, and K60 family of microcontroller (MCU) devices. The TWR-K60F120M features the Kinetis K60 low-power microcontroller based on the ARM® Cortex™-M4 architecture with USB 2.0 HS Controller, USB 2.0 full-speed OTG controller and 10/100 Mbps Ethernet MAC.

The TWR-K60F120M is available as a stand-alone product or as a kit (TWR-K60F120M-KIT) with the Tower Elevator Modules (TWR-ELEV) and the Tower Serial Module (TWR-SER). The TWR-K60F120M can also be combined with other Freescale Tower peripheral modules to create development platforms for a wide variety of applications. Figure 1 provides an overview of the Freescale Tower System.

Controller Module

- Tower MCU/MPU board
- Works stand-alone or in Tower System
- Features integrated debugging interface for easy programming and run-control via standard USB cable

Secondary Elevator

- Additional and secondary serial and expansion bus signals
- Standardized signal assignments
- Mounting holes and expansion connectors for side-mounting peripheral boards

Size

- Tower is approx. 3.5" H x 3.5" W x 3.5" D when fully assembled

Peripheral Module

- Examples include serial interface module, memory expansion module and Wi-Fi®

Primary Elevator

- Common serial and expansion bus signals
- Two 2x80 connectors on backside for easy signal access and side-mounting board (LCD module)
- Power regulation circuitry
- Standardized signal assignments
- Mounting holes

Board Connectors

- Four card-edge connectors
- Uses PCI Express® connectors (x16, 90 mm/ 3.5" long, 164 pins)

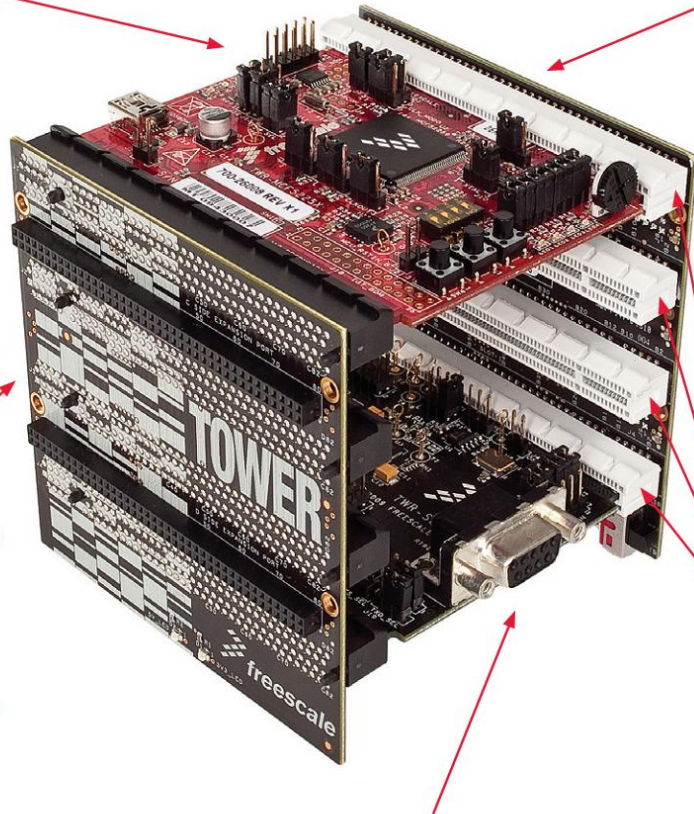

Figure 1. Freescale Tower System Overview

1.1 Contents

The TWR-K60F120M contents include:

- TWR-K60F120M board assembly
- 3ft USB cable
- Interactive DVD with software installers and documentation
- Quick Start Guide

The TWR-K60F120M-KIT contains:

- TWR-K60F120M MCU module
- TWR-ELEV – Primary and Secondary Elevator Modules
- TWR-SER – Serial module including USB host/device/OTG, Ethernet, CAN, RS232 and RS485

1.2 Features

Figure 2 and Figure 3 show the TWR-K60F120M with some of the key features called out. The following list summarizes the features of the TWR-K60F120M Tower MCU Module:

- Tower compatible microcontroller module
- MK60FN1M0VLQ12: K60FN1M in a 144 LQFP with 120 MHz operation
- Touch Tower Plug-in Socket
- General purpose Tower Plug-in (TWRPI) socket
- On-board JTAG debug circuit (OSJTAG) with virtual serial port
- 2Gb of SLC NAND flash memory
- Three axis accelerometer (MMA8451Q)
- Four (4) user-controllable LEDs
- Four (4) capacitive touch pads
- Two (2) user pushbutton switches
- Potentiometer
- Battery Holder for 20mm lithium battery (e.g. 2032, 2025)
- Micro-SD Card slot



Figure 2. Callouts on front side of the TWR-K60F120M



Figure 3. Callouts on back side of the TWR-K60F120M

1.3 Getting Started

Follow the Quick Start Guide found printed in the TWR-K60F120M box or the interactive DVD for the list of recommended steps for getting started. There are also lab walk-through guides available on the tool support page for the TWR-K60F120M: <http://www.freescale.com/TWR-K60F120M>.

1.4 Reference Documents

The documents listed below should be referenced for more information on the Kinetis family, Tower System, and MCU Modules. These can be found in the documentation section of [freescale.com/TWR-K60F120M](http://www.freescale.com/TWR-K60F120M) or [freescale.com/kinetis](http://www.freescale.com/kinetis).

- *TWR-K60F120M-QSG: Quick Start Guide*
- *TWR-K60F120M-SCH: Schematics*
- *TWR-K60F120M-PWB: Design Package*
- *K60 Family Product Brief*
- *K60 Family Reference Manual*
- *Tower Configuration Tool*

2 Hardware Description

The TWR-K60F120M is a Tower Controller Module featuring the MK60FN1M0VLQ12—an ARM Cortex-M4 based microcontroller with USB 2.0 HS Controller, USB 2.0 full-speed OTG controller and 10/100 Mbps Ethernet MAC in a 144 LQFP package with a maximum core operating frequency of 120MHz. It is intended for use in the Freescale Tower System but can operate stand-alone. An on-board debug circuit, OSJTAG, provides a JTAG debug interface and a power supply input through a single USB mini-AB connector. Figure 4 shows a block diagram of the TWR-K60F120M. The following sections describe the hardware in more detail.

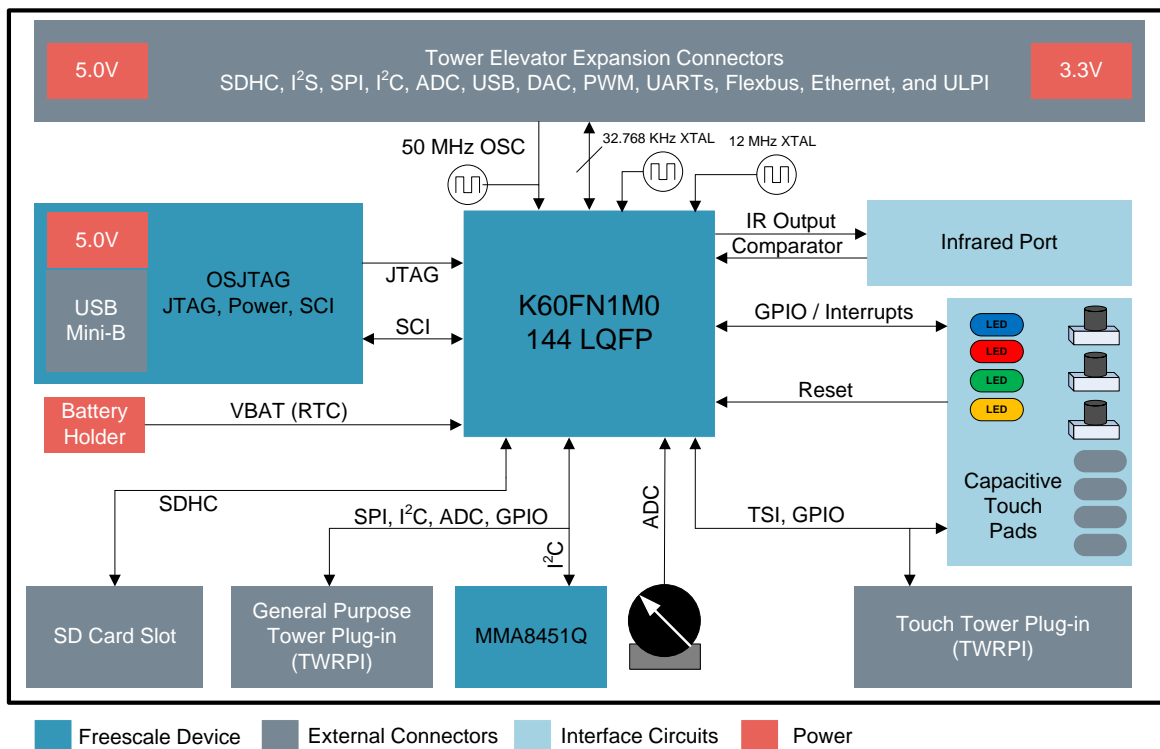

Figure 4. TWR-K60F120M Block Diagram

2.1 K60FN1M0 Microcontroller

The TWR-K60F120M module features the MK60FN1M0VLQ12. The K60 microcontroller family is part of the Kinetis portfolio of devices built around an ARM Cortex-M4 core. Refer to the *K60 Family Product Brief* and the *K60 Family Reference Manual* for comprehensive information on the MK60FN1M0VLQ12 device. The key features are listed here:

- 32-bit ARM Cortex-M4 core with DSP instructions
- 120MHz maximum core operating frequency
- 144 LQFP, 20mm x 20 mm, 0.5mm pitch package
- 1.71V – 3.6V operating voltage input range
- 1 Mbyte of program flash, 128 Kbytes of static RAM
- NAND flash controller
- External bus interface
- Power management controller with 10 different power modes
- Multi-purpose clock generator with PLL and FLL operation modes
- 16-bit SAR ADC, 12-bit DAC
- High-speed analog comparator with 6-bit DAC
- Programmable voltage reference
- USB high-speed OTG controller
- USB full-speed/low-speed OTG/Host/Device controller with device charge detect
- 10/100 Mbps Ethernet MAC
- SPI, I²C (w/ SMBUS support), UART (w/ ISO7816, CEA709.1-B (LON), and IrDA support), CAN, I²S
- SD Host Controller (SDHC)
- GPIO with pin interrupt support, DMA request capability, digital glitch filtering
- Capacitive touch sensing inputs (TSI)
- Debug interfaces: JTAG, cJTAG, SWD
- Trace: TPIO, FPB, DWT, ITM, ETM, ETB

2.2 Clocking

The Kinetis MCUs start up from an internal digitally controlled oscillator (DCO). Software can enable one, two, or three external oscillators if desired. Two of the external oscillators provide clocks to the Multipurpose Clock Generator (MCG) module and can range from 32.768 KHz up to a 32 MHz crystal or ceramic resonator. The external oscillator for the Real Time Clock (RTC) module accepts a 32.768 kHz crystal.

The EXTAL0 and EXTAL1 pins of the main external oscillators can also be driven directly from an external clock source. The TWR-K60F120M features a 50 MHz on-board clock oscillator connected to EXTAL0 as seen in sheet 4 of the schematics. However, when the K60 Ethernet MAC is operating in RMII mode, synchronization of the MCU input clock and the 50 MHz RMII transfer clock is important. In this mode, the MCU input clock must be kept in phase with the 50 MHz clock supplied to the external PHY. Therefore, the TWR-K60F120M provides the option (see description for J19 in Table 5) to select the clock input to the MCU from 1) the on-board 50MHz source or 2) an external clock from the CLKIN0 pin on the Primary Connector. When the K60 is operating in Ethernet RMII mode, the Tower peripheral module implementing the RMII PHY device should drive a 50 MHz clock on the CLKIN0 signal that is kept in phase with the clock supplied to the RMII PHY. Refer to section 2.11 “Ethernet” for more information.

The TWR-K60F120M also includes a 12MHz crystal connected to EXTAL1/XTAL1.

2.3 System Power

In stand-alone operation, the main power source for the TWR-K60F120M module is derived from the 5.0V input from either the USB mini-B connector, J13, or the debug header, J11, when a shunt is placed on jumper J12. A low-dropout regulator provides a 3.3V supply from the 5.0V input voltage. Refer to sheet 6 of the TWR-K60F120M schematics for more details.

When installed into a Tower System, the TWR-K60F120M can be powered from either an on-board source or from another source in the assembled Tower System. If both the on-board and off-board sources are available, the TWR-K60F120M will default to the off-board source.

The 3.3V power supplied to the MCU is routed through a jumpers, J8. J8 can be supplies VDD to the processor. The jumper shunt can be removed to allow for either 1) alternate MCU supply voltages to be injected or 2) the measurement of power consumed by the MCU.

2.3.1 RTC VBAT

The Real Time Clock (RTC) module on the K60 has two modes of operation, system power-up and system power-down. During system power-down, the RTC is powered from the backup power supply, VBAT. The TWR-K60F120M provides a battery holder for a coin cell battery that can be used as the VBAT supply. The holder can accept common 20mm diameter 3V lithium coin cell batteries (e.g. 2032, 2025). Refer to the description J9 in Table 5 “TWR-K60F120M Jumper Table” for more information.

2.4 Debug Interface

There are two debug interface options provided: the on-board OSJTAG circuit and an external Cortex Debug+ETM connector.

2.4.1 OSJTAG

An on-board MC9S08JM60 based Open Source JTAG (OSJTAG) circuit provides a JTAG debug interface to the K60FN1M0. A standard USB A male to Mini-B male cable (provided) can be used for debugging via the USB connector, J13. The OSJTAG interface also provides a USB to serial bridge. Drivers for the OSJTAG interface are provided in the *P&E Micro Kinetis Tower Toolkit* (available on the included DVD).

2.4.2 Cortex Debug+ETM Connector

The Cortex Debug+ETM connector is a 20-pin (0.05") connector providing access to the SWD, SWV, JTAG, cJTAG, EzPort and ETM trace (4-bit) signals available on the K60 device. The pinout and K60 pin connections to the debug connector, J14, is shown in Table 1Table 1.

NOTE: The TRACE_CLKOUT signal is not connected to the debug connector by default. In order to use trace functionality R137 should be populated and R138 and R11 should be removed.

Table 1. Cortex Debug+ETM Connector Pinout

Pin	Function	TWR-K60F120M Connection
1	VTref	3.3V MCU supply (P3V3_MCU)
2	TMS / SWDIO	PTA3/SCI0_RTS_b/FTM0_CH0/JTAG_MS/SWD_DIO
3	GND	GND
4	TCK / SWCLK	PTA0/SCI0_CTS_b/FTM0_CH5/JTAG_CLK/SWD_CLK/EZP_CLK

Pin	Function	TWR-K60F120M Connection
5	GND	GND
6	TDO / SWO	PTA2/SCI0_TX/FTM0_CH7/JTAG_DO/TRACE_SWO/EZP_DO
7	Key	—
8	TDI	PTA1/SCI0_RX/FTM0_CH6/JTAG_DI/EZP_DI
9	GNDDetect	PTA4/FTM0_CH1/MS/NMI_b/EZP_CS_b
10	nRESET	RESET_b
11	Target Power	5V supply (via J12)
12	TRACECLK	PTA6/FTM0_CH3/TRACE_CLKOUT
13	Target Power	5V supply (via J12)
14	TRACEDATA[0]	PTA10/FTM2_CH0/FTM2_QD_PHA/TRACE_DO
15	GND	GND
16	TRACEDATA[1]	PTA9/FTM1_CH1/FTM1_QD_PHB/TRACE_D1
17	GND	GND
18	TRACEDATA[2]	PTA8/FTM1_CH0/FTM1_QD_PHA/TRACE_D2
19	GND	GND
20	TRACEDATA[3]	PTA7/FTM0_CH4/TRACE_D3

Note: Many of the trace signals connected to the debug connector are also connected elsewhere on the TWR-K60F120M. Refer to Table 6 “I/O Connectors and Pin Usage Table” and Table 7 “TWR-K60F120M Primary Connector Pinout” for more information.

2.5 NAND Flash

The TWR-K60F120M includes 2Gb of SLC NAND flash memory (MT29F2G15ABAEAWP). The data lines used for the NAND flash are shared between the NAND flash controller and the FlexBus interface. Internal arbitration logic in the processor allows for dynamic sharing between the NAND flash and FlexBus interfaces.

2.6 Infrared Port

An infrared transmit and receive interface is implemented on the board. The CMT_IRO pin directly drives an infrared diode. The receiver uses an infrared phototransistor connected to an on-chip analog comparator through a low-pass filter. Internal to the K60 device, the output of the analog comparator can be routed to a UART module for easier processing of the incoming data stream.

2.7 Accelerometer

An MMA8451Q digital accelerometer is connected to the K60 MCU through an I2C interface and a GPIO/IRQ signal. Refer to Table 6 “I/O Connectors and Pin Usage Table” for connection details.

2.8 Potentiometer, Pushbuttons, LEDs

The TWR-K60F120M features two pushbutton switches connected to GPIO/interrupt signals, one pushbutton connected to the master reset signal, four capacitive touch pad electrodes, four user-controllable LEDs, and a potentiometer connected to an ADC input signal. Refer to Table 6 “I/O Connectors and Pin Usage Table” for information about which port pins are connected to these features.

2.9 General Purpose Tower Plug-in (TWRPI) Socket

The TWR-K60F120M features a socket that can accept a variety of different Tower Plug-in modules featuring sensors, RF transceivers, and more. The General Purpose TWRPI socket provides access to I2C, SPI, IRQs, GPIOs, timers, analog conversion signals, TWRPI ID signals, reset, and voltage supplies. The pinout for the TWRPI Socket is defined in Table 2.

Refer to Table 6 “I/O Connectors and Pin Usage Table” for the specific K60 pin connections to the General Purpose TWRPI socket.

Table 2. General Purpose TWRPI socket pinout

Left-side 2x10 Connector		Right-side 2x10 Connector	
Pin	Description	Pin	Description
1	5V VCC	1	GND
2	3.3 V VCC	2	GND
3	GND	3	I2C: SCL
4	3.3V VDDA	4	I2C: SDA
5	VSS (Analog GND)	5	GND
6	VSS (Analog GND)	6	GND
7	VSS (Analog GND)	7	GND
8	ADC: Analog 0	8	GND
9	ADC: Analog 1	9	SPI: MISO
10	VSS (Analog GND)	10	SPI: MOSI
11	VSS (Analog GND)	11	SPI: SS
12	ADC: Analog 2	12	SPI: CLK
13	VSS (Analog GND)	13	GND
14	VSS (Analog GND)	14	GND
15	GND	15	GPIO: GPIO0/IRQ
16	GND	16	GPIO: GPIO1/IRQ
17	ADC: TWRPI ID 0	17	GPIO: GPIO2
18	ADC: TWRPI ID 1	18	GPIO: GPIO3
19	GND	19	GPIO: GPIO4/Timer
20	Reset	20	GPIO: GPIO5/Timer

2.10 Touch Interface

The touch sensing input (TSI) module of the Kinetis MCUs provides capacitive touch sensing detection with high sensitivity and enhanced robustness. Each TSI pin implements the capacitive measurement of an electrode.

The TWR-K60F120M provides two methods for evaluating the TSI module. There are four individual electrodes on-board the TWR-K60F120M that simulate pushbuttons. Additionally, twelve TSI signals are connected to a Touch Tower Plug-in (TWRPI) socket that can accept Touch TWRPI daughter cards that may feature keypads, rotary dials, sliders, etc.

The pinout for the Touch TWRPI socket is defined in Table 3. Refer to Table 6 “I/O Connectors and Pin Usage Table” for the specific K60 pin connections to the Touch TWRPI socket.

Table 3. Touch TWRPI socket pinout

Pin	Description
1	5V VCC
2	3.3 V VCC
3	Electrode 0
4	3.3V VDDA
5	Electrode 1
6	VSS (Analog GND)
7	Electrode 2
8	Electrode 3
9	Electrode 4
10	Electrode 5
11	Electrode 6
12	Electrode 7
13	Electrode 8
14	Electrode 9
15	Electrode 10
16	Electrode 11
17	ADC: TWRPI ID 0
18	ADC: TWRPI ID 1
19	GND
20	Reset

2.11 Ethernet

The K60FN1M0 features a 10/100 Mbps Ethernet MAC with MII and RMII interfaces. The TWR-K60F120M routes the RMII interface signals from the K60 MCU to the Primary Connector, allowing the connection to an external Ethernet PHY device on a Tower peripheral module.

When the K60 Ethernet MAC is operating in RMII mode, synchronization of the MCU clock and the 50 MHz RMII transfer clock is important. The MCU input clock must be kept in phase with the 50 MHz clock supplied to the external PHY. Therefore, the TWR-K60F120M provides the option (see description for J18 in Table 5) to clock the MCU from an external clock from the CLKIN0 pin on the Primary Connector. The Tower peripheral module implementing the RMII PHY device should drive a 50 MHz clock on the CLKIN0 pin that is kept in phase with the clock supplied to the RMII PHY.

The TWR-SER module that comes as part of the TWR-K60F120M-KIT provides a 10/100 Ethernet PHY that can operate in either MII or RMII mode. By default the PHY is boot strapped to operate in MII mode; therefore jumper configuration changes may be required. Table 4 shows the settings for proper interoperability between the Ethernet interface on the TWR-SER and the TWR-K60F120M.

Table 4. Ethernet operation jumper settings

Tower Module	Jumper	Setting
TWR-K60F120M(revB)	J18	OFF
TWR-K60F120M(revC)	J6	ON

TWR-SER	J2	3-4
TWR-SER	J3	2-3
TWR-SER	J12	9-10

2.12 USB

The K60FN1M0 features two different USB modules--a USB full-speed/low-speed OTG/Host/Device controller with built-in transceiver and a high-speed OTG/Host/Device controller that requires an external ULPI PHY.

2.12.1 FS/LS USB

The TWR-K60F120M routes the USB D+ and D- signals from the K60 MCU to the Primary Connector, allowing the connection to external USB connectors or additional circuitry on a Tower peripheral module.

The TWR-SER module included as part of the TWR-K60F120M-KIT provides a USB OTG/Host/Device interface with a mini-AB USB connector. There are many configuration options that can be selected to evaluate different USB modes of operation. By default, the TWR-SER is configured for USB Device operation. Please refer to the documentation included with the TWR-SER for more information on the configuration options.

2.12.2 HS USB

The TWR-K60F120M routes the ULPI interface signals for the high-speed USB module to the Secondary Connector allowing the connection to an external ULPI PHY or additional circuitry on a Tower peripheral module.

The TWR-SER2 module includes a ULPI PHY that can be used with the TWR-K60F120M in order to evaluate the high-speed USB functionality. The TWR-SER2 is not included as part of the TWR-K60F120M-KIT, but the boards can be ordered individually from Freescale.

2.13 Secure Digital Card Slot

A Micro-Secure Digital (SD) card slot is available on the TWR-K60F120M connected to the SD Host Controller (SDHC) signals of the K60 MCU. This slot will accept micro-SD memory cards. Refer to Table 6 "I/O Connectors and Pin Usage Table" for the SDHC signal connection details.

2.14 External Bus Interface – FlexBus

The K60 device features a multi-function external bus interface called the FlexBus interface controller capable of interfacing to slave-only devices. The FlexBus interface is not used directly on the TWR-K60F120M. Instead, a subset of the FlexBus is connected to the Primary Connector so that the external bus can access devices on Tower peripheral modules. Refer to Table 7 "TWR-K60F120M Primary Connector Pinout" and sheet 9 of the TWR-K60F120M schematics for more details.

3 Jumper Table

There are several jumpers on the TWR-K60F120M that provide configuration selection and signal isolation. Refer to the following table for details. The default installed jumper settings are shown in bold with asterisks.

Table 5. TWR-K60F120M Jumper Table

Jumper	Option	Setting	Description
J1	USB VREGIN Power Connection	*ON*	Connect USB0_VBUS from Primary Elevator (A57) to VREGIN
		OFF	Disconnect VREGIN from Primary Elevator
J2	Infrared Transmitter Connection	ON	Connect PTD7/CMT_IRO/UART0_TX to IR Transmitter (D1)
		OFF	Disconnect PTD7/CMT_IRO/UART0_TX from IR Transmitter (D1)
J6 (revC board)	50 MHz oscillator output enable	ON	On-board 50MHz oscillator disabled. Off-board clock drives main EXTAL. NOTE: This option should be selected whenever a tower module card that provides a clock on primary elevator pin B24 is connected to the CPU module. Otherwise there will be contention between the two clock sources.
		OFF	On-board 50MHz oscillator enabled. On-board 50 MHz clock drives main EXTAL.
J8	MCU Power Connection	*ON*	Connect on-board 3.3V supply to MCU
		OFF	Isolate MCU from power supply (allows for external supply or power measurements)
J9	VBAT Power Selection	*1-2*	Connect VBAT to on-board 3.3V supply
		2-3	Connect VBAT to the higher voltage between on-board 3.3V supply or coin-cell supply
J10	OSJTAG Mode Selection	ON	OSJTAG bootloader mode (OSJTAG firmware reprogramming)
		OFF	Debugger mode
J12	JTAG Power Connection	ON	Connect on-board 5V supply to JTAG port (supports powering board from external JTAG probe)
		OFF	Disconnect on-board 5V supply from JTAG port
J16	Infrared Receiver Connection	ON	Connect PTC6/CMP0_IN0 to IR Receiver
		OFF	Disconnect PTC6/CMP0_IN0 to IR Receiver
J18 (revB board)	50MHz clock disable	*ON*	On-board 50MHz oscillator enabled. On-board 50 MHz clock drives main EXTAL.
		OFF	On-board 50MHz oscillator disabled. Off-board clock drives main EXTAL. NOTE: This option must be selected whenever a tower module card that provides a clock on primary elevator pin

			B24 is connected to the CPU module. Otherwise there will be contention between the two clock sources.
J18 (revC board)	50 MHz oscillator power	*ON*	Power supply to 50MHz oscillator enabled.
		OFF	Power supply to 50MHz oscillator disabled.
J19	Potentiometer Connection	*ON*	Connect ADC1_DM1 to the potentiometer
		OFF	Disconnect ADC1_DM1 from the potentiometer
J21	I2S0_TXD0 source	1-2	PTA12 is used as I2S0_TXD0 (Ethernet cannot be used when this option is selected)
		2-3	PTC1 is used as I2S0_TXD0 (NFC cannot be used when this option is selected)
J22	I2S0_TX_FS source	1-2	PTA13 is used as I2S0_TX_FS (Ethernet cannot be used when this option is selected)
		2-3	PTC2 is used as I2S0_TX_FS (NFC cannot be used when this option is selected)
J23	I2S0_RX_BCLK/I2S0_TXD1 source	1-2	PTA14 is used as I2S0_RX_BCLK/I2S0_TXD1 (Ethernet cannot be used when this option is selected)
		2-3	PTC0 is used as I2S0_RX_BCLK/I2S0_TXD1 (NFC cannot be used when this option is selected)
J24	I2S0_RX_FS/I2S0_RXD1 source	1-2	PTA16 is used as I2S0_RX_FS/I2S0_RXD1 (Ethernet cannot be used when this option is selected)
		2-3	PTC11 is used as I2S0_RX_FS/I2S0_RXD1 (NFC cannot be used when this option is selected)

4 Input/Output Connectors and Pin Usage Table

The following table provides details on which K60FN1M0 pins are used to communicate with the LEDs, switches, and other I/O interfaces onboard the TWR-K60F120M.

Note: Some port pins are used in multiple interfaces on-board and many are potentially connected to off-board resources via the Primary and Secondary Connectors. Take care to avoid attempted simultaneous usage of mutually exclusive features.

Table 6. I/O Connectors and Pin Usage Table

Feature	Connection	Port Pin	Pin Function
OSJTAG USB-to-serial Bridge	OSJTAG Bridge RX Data	PTE9	UART5_RX
	OSJTAG Bridge TX Data	PTE8	UART5_TX
SD Card Slot	SD Clock	PTE2	SDHC0_DCLK
	SD Command	PTE3	SDHC0_CMD
	SD Data0	PTE1	SDHC0_D0
	SD Data1	PTE0	SDHC0_D1
	SD Data2	PTE5	SDHC0_D2
	SD Data3	PTE4	SDHC0_D3
	SD Card Detect	PTE28	PTE28
Infrared Port	IR Transmit	PTD7	CMT_IRO
	IR Receive	PTC6	CMPO_IN0
Pushbuttons	SW1 (IRQ0)	PTA19	PTA19
	SW2 (IRQ1)	PTE26	PTE26

	SW3 (RESET)	RESET_b	RESET_b
Touch Pads	E1 / Touch	PTA4	TSIO_CH5
	E2 / Touch	PTB3	TSIO_CH8
	E3 / Touch	PTB2	TSIO_CH7
	E4 / Touch	PTB16	TSIO_CH9
LEDs	E1 / Orange LED	PTA11	PTA11
	E2 / Yellow LED	PTA28	PTA28
	E3 / Green LED	PTA29	PTA29
	E4 / Blue LED	PTA10	PTA10
Potentiometer	Potentiometer (R52)	—	ADC1_DM1
Accelerometer	I2C SDA	PTD9	I2CO_SDA
	I2C SCL	PTD8	I2CO_SCL
	INT1	PTB4	PTB4
	INT2	PTB7	PTB7
General Purpose TWRPI Socket	TWRPI AN0 (J4 Pin 8)	—	ADC0_DP0/ADC1_DP3
	TWRPI AN1 (J4 Pin 9)	—	ADC0_DM0/ADC1_DM3
	TWRPI AN2 (J4 Pin 12)	—	ADC1_DP0/ADC0_DP3
	TWRPI ID0 (J4 Pin 17)	—	ADC0_DP1/ADC2_DP0/ADC3_DP3
	TWRPI ID1 (J4 Pin 18)	—	ADC0_DM1/ADC2_DM0/ADC3_DM3
	TWRPI I2C SCL (J5 Pin 3)	PTD8	I2CO_SCL
	TWRPI I2C SDA (J5 Pin 4)	PTD9	I2CO_SDA
	TWRPI SPI MISO (J5 Pin 9)	PTD14	SPI2_SIN
	TWRPI SPI MOSI (J5 Pin 10)	PTD13	SPI2_SOUT
	TWRPI SPI SS (J5 Pin 11)	PTD15	SPI2_PCS1
	TWRPI SPI CLK (J5 Pin 12)	PTD12	SPI2_SCK
	TWRPI GPIO0 (J5 Pin 15)	PTD10	PTB4
	TWRPI GPIO1 (J5 Pin 16)	PTB8	PTB8
	TWRPI GPIO2 (J5 Pin 17)	PTB9	PTB9
TWRPI GPIO3 (J5 Pin 18)	PTA19	PTA19	
TWRPI GPIO4 (J5 Pin 19)	PTE26	PTE26	
Touch Pad / Segment LCD TWRPI Socket	Electrode 0 (J3 Pin 3)	PTB0	TSIO_CH0
	Electrode 1 (J3 Pin 5)	PTB1	TSIO_CH6
	Electrode 2 (J3 Pin 7)	PTB2	TSIO_CH7
	Electrode 3 (J3 Pin 8)	PTB3	TSIO_CH8
	Electrode 4 (J3 Pin 9)	PTC0	TSIO_CH13
	Electrode 5 (J3 Pin 10)	PTC1	TSIO_CH14
	Electrode 6 (J3 Pin 11)	PTC2	TSIO_CH15
	Electrode 7 (J3 Pin 12)	PTA4	TSIO_CH5
	Electrode 8 (J3 Pin 13)	PTB16	TSIO_CH9
	Electrode 9 (J3 Pin 14)	PTB17	TSIO_CH10
	Electrode 10 (J3 Pin 15)	PTB18	TSIO_CH11
	Electrode 11 (J3 Pin 16)	PTB19	TSIO_CH12

	TWRPI ID0 (J3 Pin 17)	—	ADC1_DP1
	TWRPI ID1 (J3 Pin 18)	—	ADC1_SE16

5 Tower Elevator Connections

The TWR-K60F120M features two expansion card-edge connectors that interface to the Primary and Secondary Elevator boards in a Tower system. The Primary Connector (comprised of sides A and B) is utilized by the TWR-K60F120M while the Secondary Connector (comprised of sides C and D) only makes connections to the GND pins. Table 7 provides the pinout for the Primary Connector.

Table 7. TWR-K60F120M Primary Connector Pinout

TWR-K60F120M Primary Connector							
Pin #	Side B			Pin #	Side A		
	Name	Group	Usage		Name	Group	Usage
B1	5V	Power	5.0V Power	A1	5V	Power	5.0V Power
B2	GND	Power	Ground	A2	GND	Power	Ground
B3	3.3V	Power	3.3V Power	A3	3.3V	Power	3.3V Power
B4	ELE_PS_SENSE	Power	Elevator Power Sense	A4	3.3V	Power	3.3V Power
B5	GND	Power	Ground	A5	GND	Power	Ground
B6	GND	Power	Ground	A6	GND	Power	Ground
B7	SDHC_CLK / SPI1_CLK	SDHC / SPI 1	PTE2	A7	SCL0	I2C 0	PTD8
B8	SDHC_D3 / SPI1_CS1_b	SDHC / SPI 1		A8	SDA0	I2C 0	PTD9
B9	SDHC_D3 / SPI1_CS0_b	SDHC / SPI 1	PTE4	A9	GPIO9 / CTS1	GPIO / UART	PTE10
B10	SDHC_CMD / SPI1_MOSI	SDHC / SPI 1	PTE3	A10	GPIO8 / SDHC_D2	GPIO / SDHC	PTE5
B11	SDHC_D0 / SPI1_MISO	SDHC / SPI 1	PTE1	A11	GPIO7 / SD_WP_DET	GPIO / SDHC	PTE27
B12	ETH_COL	Ethernet		A12	ETH_CRS	Ethernet	
B13	ETH_RXER	Ethernet	PTA5	A13	ETH_MDC	Ethernet	PTB1
B14	ETH_TXCLK	Ethernet		A14	ETH_MDIO	Ethernet	PTB0
B15	ETH_TXEN	Ethernet	PTA15	A15	ETH_RXCLK	Ethernet	
B16	ETH_TXER	Ethernet		A16	ETH_RXDV	Ethernet	PTA14
B17	ETH_TXD3	Ethernet		A17	ETH_RXD3	Ethernet	
B18	ETH_TXD2	Ethernet		A18	ETH_RXD2	Ethernet	
B19	ETH_TXD1	Ethernet	PTA17	A19	ETH_RXD1	Ethernet	PTA12

B2 0	ETH_TXD0	Ethernet	PTA16	A2 0	ETH_RXD0	Ethernet	PTA13
B2 1	GPIO1 / RTS1	GPIO / UART	PTE11	A2 1	SSI_MCLK	SSI	PTE6
B2 2	GPIO2 / SDHC_D1	GPIO / SDHC	PTE0	A2 2	SSI_BCLK	SSI	PTE12
B2 3	GPIO3	GPIO	PTE28	A2 3	SSI_FS	SSI	PTA13/PTC2 (determined by J22)
B2 4	CLKIN0	Clock	PTA18	A2 4	SSI_RXD	SSI	PTE7
B2 5	CLKOUT1	Clock	PTE26	A2 5	SSI_TXD	SSI	PTA12/PTC1 (determined by J21)
B2 6	GND	Power	Ground	A2 6	GND	Power	Ground
B2 7	AN7	ADC	PTB7	A2 7	AN3	ADC	PGA0_DP/ADC0_DP0/A DC1_DP3
B2 8	AN6	ADC	PTB6	A2 8	AN2	ADC	PGA0_DM/ADC0_DM0/ ADC1_DM3
B2 9	AN5	ADC	PTB5	A2 9	AN1	ADC	PGA1_DP/ADC1_DP0/A DC0_DP3
B3 0	AN4	ADC	PTB4	A3 0	AN0	ADC	PGA1_DM/ADC1_DM0/ ADC0_DM3
B3 1	GND	Power	Ground	A3 1	GND	Power	Ground
B3 2	DAC1	DAC	DAC1_OUT	A3 2	DAC0	DAC	DAC0_OUT
B3 3	TMR3	Timer		A3 3	TMR1	Timer	PTA9
B3 4	TMR2	Timer	PTD6	A3 4	TMR0	Timer	PTA8
B3 5	GPIO4	GPIO	PTB8	A3 5	GPIO6	GPIO	PTB9
B3 6	3.3V	Power	3.3V Power	A3 6	3.3V	Power	3.3V Power
B3 7	PWM7	PWM	PTA2	A3 7	PWM3	PWM	PTA6
B3 8	PWM6	PWM	PTA1	A3 8	PWM2	PWM	PTC3
B3 9	PWM5	PWM	PTD5	A3 9	PWM1	PWM	PTC2
B4 0	PWM4	PWM	PTA7	A4 0	PWM0	PWM	PTC1
B4 1	CANRX0	CAN 0	PTC16	A4 1	RXD0	UART 0	PTA1
B4 2	CANTX0	CAN 0	PTC17	A4 2	TXD0	UART 0	PTA2
B4 3	1WIRE	1-Wire		A4 3	RXD1	UART 1	PTE9
B4 4	SPIO_MISO	SPI 0	PTD14	A4 4	TXD1	UART 1	PTE8
B4 5	SPIO_MOSI	SPI 0	PTD13	A4 5	VSS	Analog Vref	VSSA
B4 6	SPIO_CS0_b	SPI 0	PTD11	A4 6	VDDA	Analog Vref	VDDA

B4 7	SPI0_CS1_b	SPI 0	PTD15	A4 7	CANRX1	CAN 1	
B4 8	SPI0_CLK	SPI 0	PTD12	A4 8	CANTX1	CAN 1	
B4 9	GND	Power	Ground	A4 9	GND	Power	Ground
B5 0	SCL1	I2C 1	PTD8	A5 0	GPIO14	GPIO	
B5 1	SDA1	I2C 1	PTD9	A5 1	GPIO15	GPIO	
B5 2	GPIO5 / SD_CARD_DET	GPIO / SDHC	PTE28	A5 2	GPIO16	GPIO	
B5 3	RSRV_B53	USB 0		A5 3	GPIO17	GPIO	
B5 4	RSRV_B54	USB 0		A5 4	USB0_DM	USB 0	USB0_DM
B5 5	IRQ_H	Interrupt	PTB4	A5 5	USB0_DP	USB 0	USB0_DP
B5 6	IRQ_G	Interrupt	PTB4	A5 6	USB0_ID	USB 0	
B5 7	IRQ_F	Interrupt	PTB5	A5 7	USB0_VBUS	USB 0	VREGIN
B5 8	IRQ_E	Interrupt	PTB5	A5 8	I2S0_DIN_SC K	I2S	PTA14/PTC0 (determined by J23)
B5 9	IRQ_D	Interrupt	PTB6	A5 9	I2S0_DIN_WS	I2S	PTA16/PTC11 (determined by J24)
B6 0	IRQ_C	Interrupt	PTB6	A6 0	I2S0_DIN1	I2S	PTA16/PTC11 (determined by J24)
B6 1	IRQ_B	Interrupt	PTB7	A6 1	I2S0_DOUT1	I2S	PTA14/PTC0 (determined by J23)
B6 2	IRQ_A	Interrupt	PTB7	A6 2	RSTIN_b	Reset	RESET_b
B6 3	EBI_ALE / EBI_CS1_b	EBI	PTD0	A6 3	RSTOUT_b	Reset	PTB8
B6 4	EBI_CS0_b	EBI	PTD1	A6 4	CLKOUT0	Clock	PTC3
B6 5	GND	Power	Ground	A6 5	GND	Power	Ground
B6 6	EBI_AD15	EBI	PTB18	A6 6	EBI_AD14	EBI	PTC0
B6 7	EBI_AD16	EBI	PTB17	A6 7	EBI_AD13	EBI	PTC1
B6 8	EBI_AD17	EBI	PTB16	A6 8	EBI_AD12	EBI	PTC2
B6 9	EBI_AD18	EBI	PTB11	A6 9	EBI_AD11	EBI	PTC4
B7 0	EBI_AD19	EBI	PTB10	A7 0	EBI_AD10	EBI	PTC5
B7 1	EBI_R/W_b	EBI	PTC11	A7 1	EBI_AD9	EBI	PTC6
B7 2	EBI_OE_b	EBI	PTB19	A7 2	EBI_AD8	EBI	PTC7
B7 3	EBI_D7	EBI	PTB20	A7 3	EBI_AD7	EBI	PTC8

B7 4	EBI_D6	EBI	PTB21	A7 4	EBI_AD6	EBI	PTC9
B7 5	EBI_D5	EBI	PTB22	A7 5	EBI_AD5	EBI	PTC10
B7 6	EBI_D4	EBI	PTB23	A7 6	EBI_AD4	EBI	PTD2
B7 7	EBI_D3	EBI	PTC12	A7 7	EBI_AD3	EBI	PTD3
B7 8	EBI_D2	EBI	PTC13	A7 8	EBI_AD2	EBI	PTD4
B7 9	EBI_D1	EBI	PTC14	A7 9	EBI_AD1	EBI	PTD5
B8 0	EBI_D0	EBI	PTC15	A8 0	EBI_AD0	EBI	PTD6
B8 1	GND	Power	Ground	A8 1	GND	Power	Ground
B8 2	3.3V	Power	3.3V Power	A8 2	3.3V	Power	3.3V Power

Table 8. TWR-K60F120M Secondary Connector Pinout

TWR-K60F120M Secondary Connector							
Pin #	Side D			Pin #	Side C		
	Name	Group	Usage		Name	Group	Usage
D1	5V	Power	5.0V Power	C1	5V	Power	5.0V Power
D2	GND	Power	Ground	C2	GND	Power	Ground
D3	3.3V	Power	3.3V Power	C3	3.3V	Power	3.3V Power
D4	ELE_PS_SENSE	Power	Elevator Power Sense	C4	3.3V	Power	3.3V Power
D5	GND	Power	Ground	C5	GND	Power	Ground
D6	GND	Power	Ground	C6	GND	Power	Ground
D7	SPI2_CLK	SPI 2		C7	SCL2	I2C 2	
D8	SPI2_CS1_b	SPI 2		C8	SDA2	I2C 2	
D9	SPI2_CS0_b	SPI 2		C9	GPIO25	GPIO	
D10	SPI2_MOSI	SPI 2		C10	ULPI_STOP	ULPI	PTA9
D11	SPI2_MISO	SPI 2		C11	ULPI_CLK	ULPI	PTA6
D12	ETH_COL	Ethernet		C12	GPIO26	GPIO	
D13	ETH_RXER	Ethernet		C13	ETH_MDC	Ethernet	
D14	ETH_TXCLK	Ethernet		C14	ETH_MDIO	Ethernet	
D15	ETH_TXEN	Ethernet		C15	ETH_RXCLK	Ethernet	
D16	GPIO18	GPIO		C16	ETH_RXDV	Ethernet	

D1 7	GPIO19 / SDHC_D4	GPIO / SDHC		C1 7	GPIO27 / SDHC_D6	GPIO / SDHC	
D1 8	GPIO20 / SDHC_D5	GPIO / SDHC		C1 8	GPIO28 / SDHC_D7	GPIO / SDHC	
D1 9	ETH_TXD1	Ethernet		C1 9	ETH_RXD1	Ethernet	
D2 0	ETH_TXD0	Ethernet		C2 0	ETH_RXD0	Ethernet	
D2 1	ULPI_NEXT / USB1_DM	ULPI / USB 1	PTA8	C2 1	ULPI_DATA0 / USB3_DM	ULPI / USB 3	PTA10
D2 2	ULPI_DIR / USB1_DP	ULPI / USB 1	PTA7	C2 2	ULPI_DATA1 / USB3_DP	ULPI / USB 3	PTA11
D2 3	UPLI_DATA5 / USB2_DM	ULPI / USB 2	PTA27	C2 3	ULPI_DATA2 / USB4_DM	ULPI / USB 4	PTA24
D2 4	ULPI_DATA6 / USB2_DP	ULPI / USB 2	PTA28	C2 4	ULPI_DATA3 / USB4_DP	ULPI / USB 4	PTA25
D2 5	ULPI_DATA7	ULPI	PTA29	C2 5	ULPI_DATA4	ULPI	PTA26
D2 6	GND	Power	Ground	C2 6	GND	Power	Ground
D2 7	LCD_HSYNC / LCD_P24	Display		C2 7	AN11	ADC	
D2 8	LCD_VSYNC / LCD_P25	Display		C2 8	AN10	ADC	
D2 9	AN13	ADC		C2 9	AN9	ADC	
D3 0	AN12	ADC		C3 0	AN8	ADC	
D3 1	GND	Power	Ground	C3 1	GND	Power	Ground
D3 2	LCD_CLK / LCD_P26	Display		C3 2	GPIO29	GPIO	
D3 3	TMR11	Timer		C3 3	TMR9	Timer	
D3 4	TMR10	Timer		C3 4	TMR8	Timer	
D3 5	GPIO21	GPIO		C3 5	GPIO30	GPIO	
D3 6	3.3V	Power	3.3V Power	C3 6	3.3V	Power	3.3V Power
D3 7	PWM15	PWM		C3 7	PWM11	PWM	
D3 8	PWM14	PWM		C3 8	PWM10	PWM	
D3 9	PWM13	PWM		C3 9	PWM9	PWM	
D4 0	PWM12	PWM		C4 0	PWM8	PWM	
D4 1	CANRX1	CAN 1		C4 1	RXD2 / TSI0	UART 2 / TSI	
D4 2	CANTX1	CAN 1		C4 2	TXD2 / TSI1	UART 2 / TSI	
D4 3	LCD_CONTRAST	Display		C4 3	RTS2 / TSI2	UART 2 / TSI	

D4 4	LCD_OE / LCD_P27	Display		C4 4	CTS2 / TSI3	UART 2 / TSI	
D4 5	LCD_D0 / LCD_P0	Display		C4 5	RXD3 / TSI4	UART 3 / TSI	
D4 6	LCD_D1 / LCD_P1	Display		C4 6	TXD3 / TSI5	UART 3 / TSI	
D4 7	LCD_D2 / LCD_P2	Display		C4 7	RTS3 / TSI6	UART 3 / TSI	
D4 8	LCD_D3 / LCD_P3	Display		C4 8	CTS3 / TSI7	UART 3 / TSI	
D4 9	GND	Power	Ground	C4 9	GND	Power	Ground
D5 0	GPIO23	GPIO		C5 0	LCD_D4 / LCD_P4	Display	
D5 1	GPIO24	GPIO		C5 1	LCD_D5 / LCD_P5	Display	
D5 2	LCD_D12 / LCD_P12	Display		C5 2	LCD_D6 / LCD_P6	Display	
D5 3	LCD_D13 / LCD_P13	Display		C5 3	LCD_D7 / LCD_P7	Display	
D5 4	LCD_D14 / LCD_P14	Display		C5 4	LCD_D8 / LCD_P8	Display	
D5 5	IRQ_P / SPI2_CS2_b	Interrupt / SPI 2	PTB4	C5 5	LCD_D9 / LCD_P9	Display	
D5 6	IRQ_O / SPI2_CS3_b	Interrupt / SPI 2	PTB4	C5 6	LCD_D10 / LCD_P10	Display	
D5 7	IRQ_N	Interrupt	PTB5	C5 7	LCD_D11 / LCD_P11	Display	
D5 8	IRQ_M	Interrupt	PTB5	C5 8	TMR16	Timer	
D5 9	IRQ_L	Interrupt	PTB6	C5 9	TMR15	Timer	
D6 0	IRQ_K	Interrupt	PTB6	C6 0	TMR14	Timer	
D6 1	IRQ_J	Interrupt	PTB7	C6 1	TMR13	Timer	
D6 2	IRQ_I	Interrupt	PTB7	C6 2	LCD_D15 / LCD_P15	Display	
D6 3	LCD_D18 / LCD_P18	Display		C6 3	LCD_D16 / LCD_P16	Display	
D6 4	LCD_D19 / LCD_P19	Display		C6 4	LCD_D17 / LCD_P17	Display	
D6 5	GND	Power	Ground	C6 5	GND	Power	Ground
D6 6	EBI_AD20 / LCD_P42	EBI / Display		C6 6	EBI_BE_32_24_b / LCD_P28	EBI / Display	
D6 7	EBI_AD21 / LCD_P43	EBI / Display		C6 7	EBI_BE_23_16_b / LCD_P29	EBI / Display	
D6 8	EBI_AD22 / LCD_P44	EBI / Display		C6 8	EBI_BE_15_8_b / LCD_P30	EBI / Display	
D6 9	EBI_AD23 / LCD_P45	EBI / Display		C6 9	EBI_BE_7_0_b / LCD_P31	EBI / Display	
D7 0	EBI_AD24 / LCD_P46	EBI / Display		C7 0	EBI_TSIZE0 / LCD_P32	EBI / Display	

D7 1	EBI_AD25 / LCD_P47	EBI / Display		C7 1	EBI_TSIZE1 / LCD_P33	EBI / Display	
D7 2	EBI_AD26 / LCD_P48	EBI / Display		C7 2	EBI_TS_b / LCD_P34	EBI / Display	
D7 3	EBI_AD27 / LCD_P49	EBI / Display		C7 3	EBI_TBST_b / LCD_P35	EBI / Display	
D7 4	EBI_AD28 / LCD_P50	EBI / Display		C7 4	EBI_TA_b / LCD_P36	EBI / Display	
D7 5	EBI_AD29 / LCD_P51	EBI / Display		C7 5	EBI_CS4_b / LCD_P37	EBI / Display	
D7 6	EBI_AD30 / LCD_P52	EBI / Display		C7 6	EBI_CS3_b / LCD_P38	EBI / Display	
D7 7	EBI_AD31 / LCD_P53	EBI / Display		C7 7	EBI_CS2_b / LCD_P39	EBI / Display	
D7 8	LCD_D20 / LCD_P20	Display		C7 8	EBI_CS1_b / LCD_P40	EBI / Display	
D7 9	LCD_D21 / LCD_P21	Display		C7 9	GPIO31 / LCD_P41	GPIO	
D8 0	LCD_D22 / LCD_P22	Display		C8 0	LCD_D23 / LCD_P23	Display	
D8 1	GND	Power	Ground	C8 1	GND	Power	Ground
D8 2	3.3V	Power	3.3V Power	C8 2	3.3V	Power	3.3V Power