

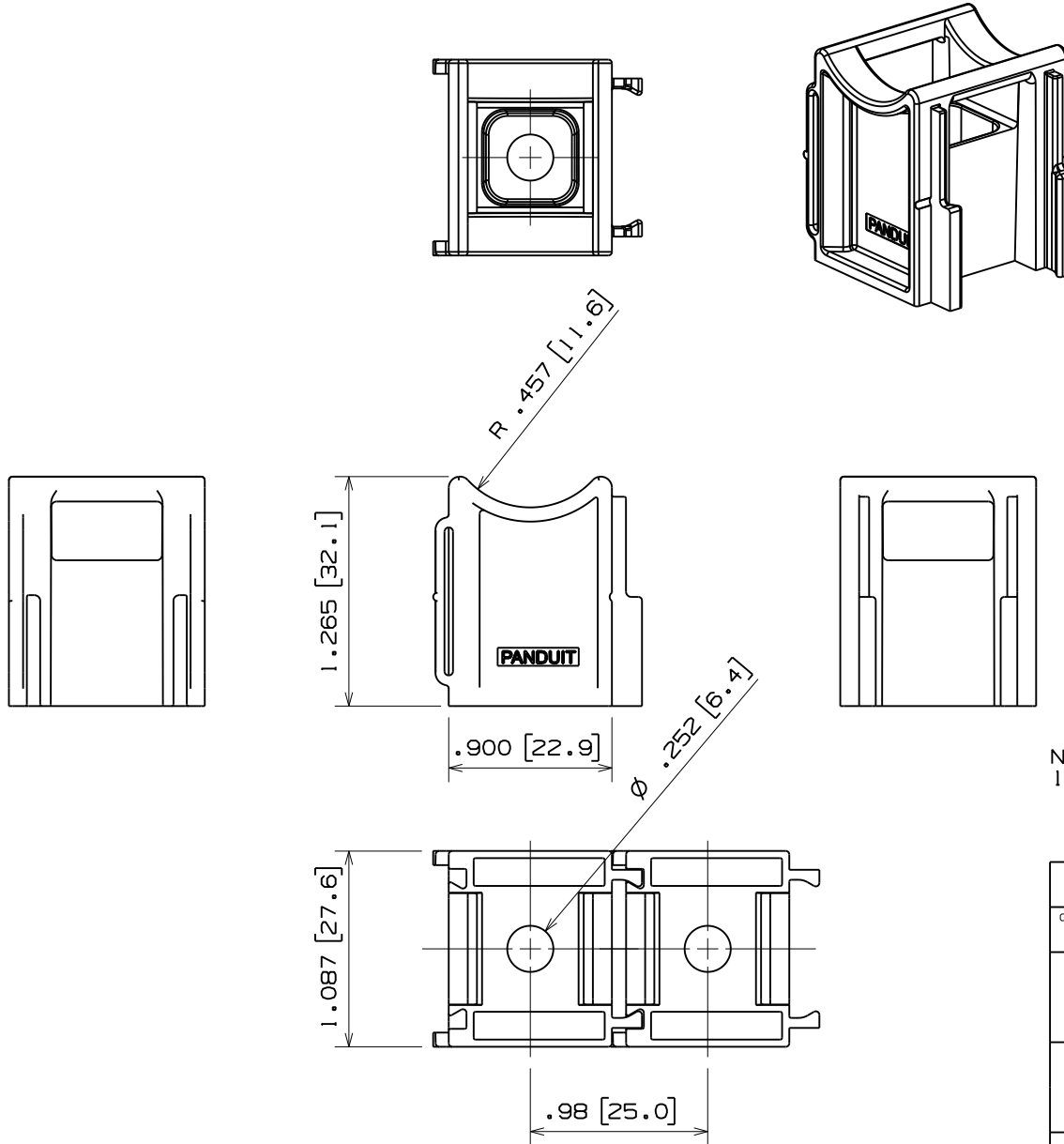

THIS COPY IS PROVIDED ON A RESTRICTED BASIS AND IS NOT TO BE USED IN ANY WAY DETRIMENTAL TO THE INTERESTS OF PANDUIT CORP.



NOTES:
 1. SEE WWW.PANDUIT.COM FOR PART NUMBER SUFFIX DESIGNATION FOR PACKAGE SIZE.

DIMENSIONS IN BRACKETS ARE METRIC [mm]	
CAD FILENAME/LAYERS 10B015CL_DC_GB3687BA_REV01	
 CORP. TINLEY PARK, ILLINOIS	
OMTM-S25 ON MACHINE TIE MOUNT	
UNLESS OTHERWISE SPECIFIED, DIMENSIONAL TOLERANCES ARE: (.X) ±0.05 (1.3) (.XXX) ±0.010 (0.25) (.XX) ±0.02 (0.5) ANGLES ±5°	UNLESS OTHERWISE SPECIFIED, ALL DIMENSIONS ARE GIVEN IN INCHES, THIRD ANGLE PROJECTION.
DRAWN BY KLN	MAT'L: NYLON 6/6
DATE 11/2/09	SCALE 1 : 1
CHK'D	DRAWING NO. GB3687BA
	DWG SIZE A

01	2/08/11	BWG	MJVE	MADE PART NUMBER OMTM-S25. REVISE NOTE TO SHOW PANDUIT.COM.	GB3678BA	01	PBC		
REV	DATE	BY	CHK	DESCRIPTION	ECN	- R	CUST	SUP	