

May.1.2017 Copyright 2017 HIROSE ELECTRIC CO., LTD. All Rights Reserved.

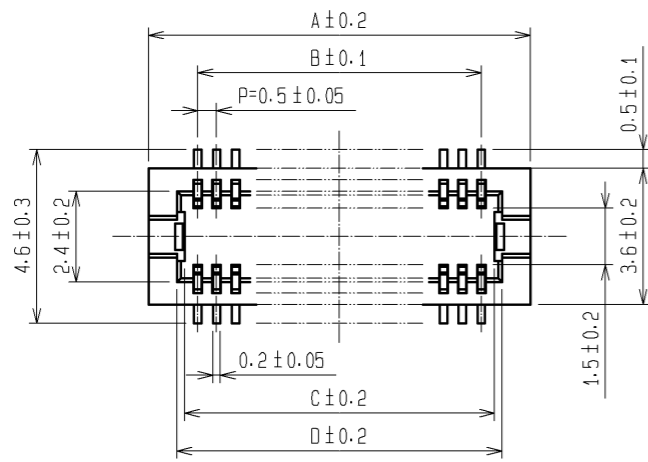

F-F (10:1)

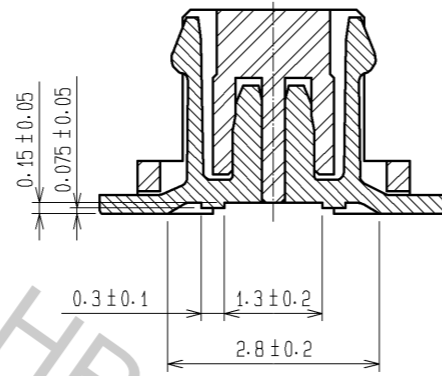

CODE No.	CONTACT	A	B	C	D	E
CL537-0203-5-81	20	7.1	4.5	5.2	5.6	5.3
CL537-0205-0-81	30	9.6	7.0	7.7	8.1	7.8
CL537-0212-6-81	32	10.1	7.5	8.2	8.6	8.3
CL537-0206-3-81	36	11.1	8.5	9.2	9.6	9.3
CL537-0207-6-81	40	12.1	9.5	10.2	10.6	10.3
CL537-0209-1-81	50	14.6	12.0	12.7	13.1	12.8
CL537-0211-3-81	60	17.1	14.5	15.2	15.6	15.3

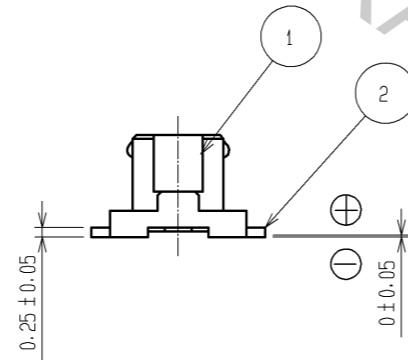
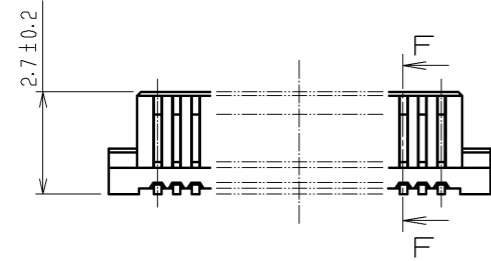

RECOMMEND METAL MASK PATTERN (10:1)

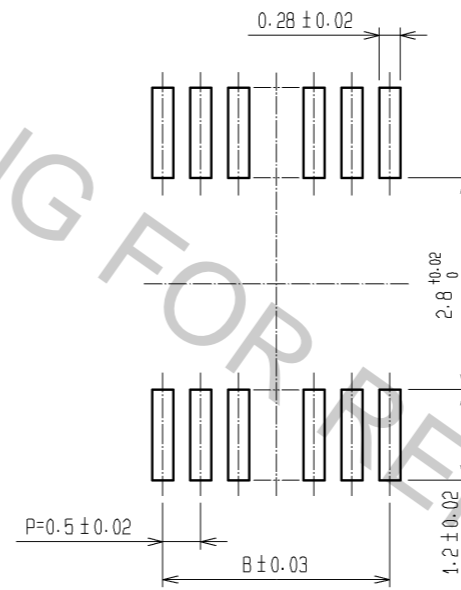

RECOMMENDED LAND PATTERN (10:1)

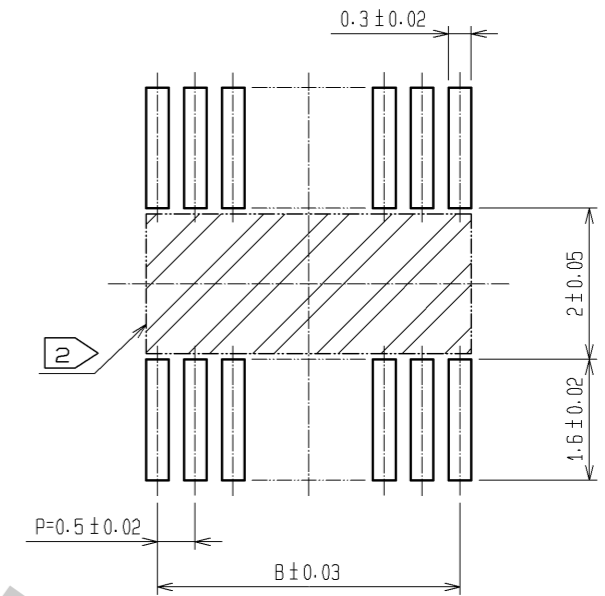

RECOMMENDED THICKNESS OF SOLDER PASTE : 120 μm

NOTES 1 LEAD CO-PLANARITY SHALL BE 0.08 mm MAX.  
 2 IF THERE IS PATTERN ON [Hatched] PART, THERE IS A POSSIBILITY THAT IT WILL MAKE CONTACT WITH THE LEADS.

NO.	MATERIAL	FINISH	REMARKS	NO.	MATERIAL	FINISH	REMARKS
2	PHOSPHOR BRONZE		CONTACT AREA:GOLD PLATED 0.2μm min LEAD AREA:GOLD PLATED 0.015μm min OTHERS(UNDER PLATING):NICKEL PLATED 2μm min	6	PS		CLEAR (REINFORCEMENT COLLAR)
				5	PS		BLACK (PLASTIC REEL)
				4	POLYESTER		CLEAR (COVER TAPE)
1	POLYAMIDE		UL94V-0, NATURAL (BEIGE)	3	PS		CLEAR (EMBOSSED CARRIER TAPE)

  

UNITS	SCALE	COUNT	DESCRIPTION OF REVISIONS	DESIGNED	CHECKED	DATE
mm	5:1	△	APPROVED : KH. IKEDA 12.04.17 CHECKED : YH. MICHIDA 12.04.17 DESIGNED : YN. SAKAMOTO 12.04.16 DRAWN : YN. SAKAMOTO 12.04.16			

DRAWING NO.	PART NO.	CODE NO.
EDC3-163506-77	DF12C-*DS-0.5V(81)	CL537

STYLE AND DIMENTION OF REEL (FREE)

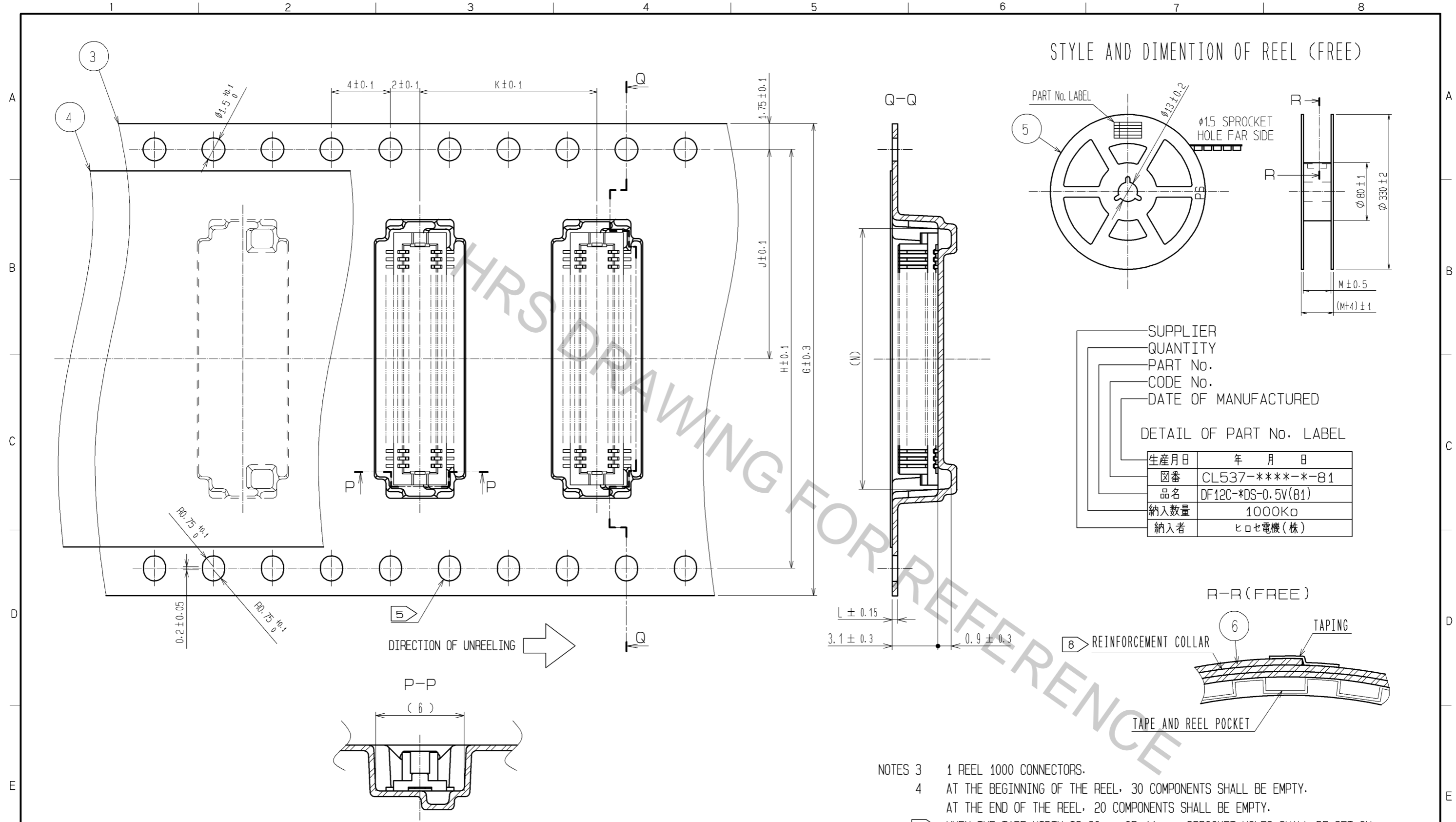

SUPPLIER  
QUANTITY  
PART No.  
CODE No.  
DATE OF MANUFACTURED

DETAIL OF PART No. LABEL

生産月日	年 月 日
図番	CL537-****-*-81
品名	DF12C-DS-0.5V(81)
納入数量	1000コ
納入者	ヒロセ電機(株)

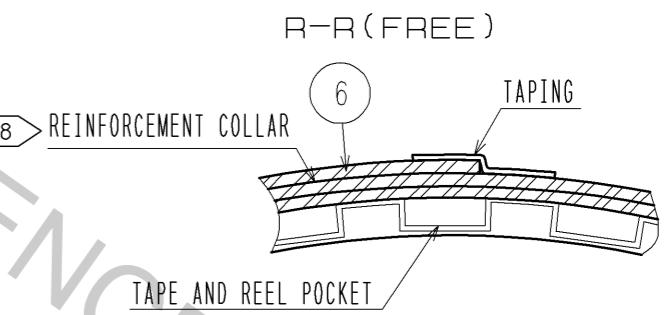

- NOTES
- 3 1 REEL 1000 CONNECTORS.
  - 4 AT THE BEGINNING OF THE REEL, 30 COMPONENTS SHALL BE EMPTY.  
AT THE END OF THE REEL, 20 COMPONENTS SHALL BE EMPTY.
  - 5 WHEN THE TAPE WIDTH IS 32 mm OR 44 mm, SPROCKET HOLES SHALL BE SET ON BOTH SIDE OF REEL AS SHOWN ON THIS DRAWING.
  - 6 PEEL FORCE REFERS TO JIS C 0806.
  - 7 THE REEL IS PACKED WITH A POLYETHYLENE MATERIAL, TOGETHER WITH A DRYING AGENT.
  - 8 AFTER PACKING, ROLL 2 METERS OF THE REINFORCEMENT COLLAR TO OUTER CIRCUMFERENCE OF TAPE AND REEL POCKET, AND TAPE DOWN AT THE END THE COLLAR.

CODE No.	CONTACT	G	H	J	K	L	M	N
CL537-0203-5-81	20	16	-	7.5	12	0.38	17.5	9
CL537-0205-0-81	30	24	-	11.5	12	0.38	25.5	11.5
CL537-0212-6-81	32	24	-	11.5	12	0.30	25.5	12
CL537-0206-3-81	36	24	-	11.5	8	0.30	25.5	12.6
CL537-0207-6-81	40	24	-	11.5	12	0.38	25.5	14
CL537-0209-1-81	50	24	-	11.5	8	0.30	25.5	16.1
CL537-0211-3-81	60	32	28.4	14.2	12	0.30	33.5	18.6

<b>HRS</b>	DRAWING NO.	EDC3-163506-77
	PART NO.	DF12C-DS-0.5V(81)
	CODE NO.	CL537
		△ 2/2