

LOC	DIST	ZONE	LTR	DESCRIPTION	DATE	APPD
G	14			REVISED PER 0720-0230-93	2/25/94	DUP

METRIOR
 DIMENSIONS LISTED IN MM [INCHES]

AMP WIRE RANGE 12-10 AWG STRANDED	UL E13288 Listed 12-10 AWG STRANDED
LR7189 Certified	MILITARY P/N AND CLASS
NOT CERTIFIED	NOT APPLICABLE

△ STAMP AMP 12-10* APPROX AS SHOWN

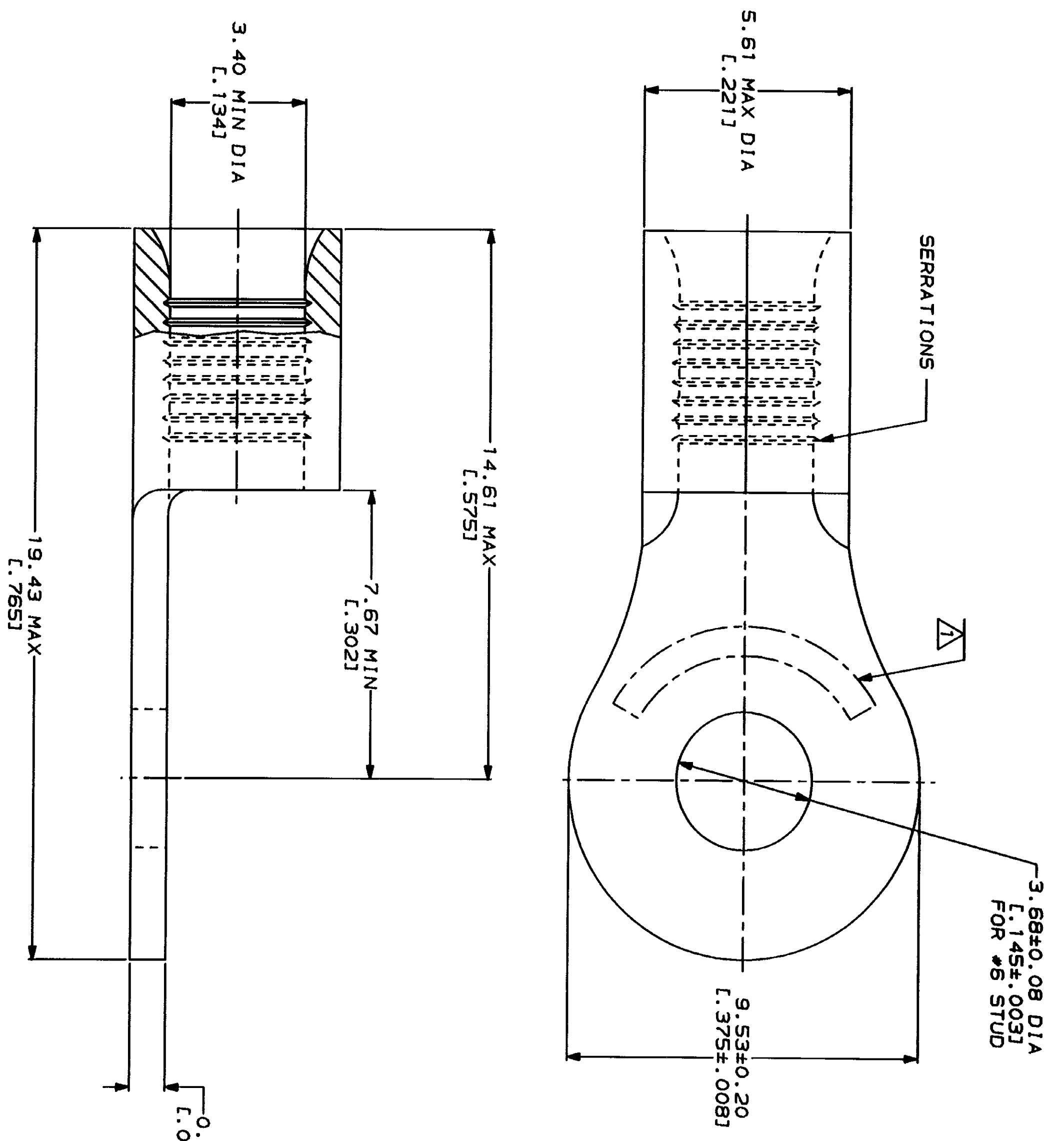

AMP INCORPORATED
 CUSTOMER SERVICE SYSTEMS

FOR ADDITIONAL
 PRODUCT INFORMATION OR
 COPIES OF DRAWINGS
 AND TECHNICAL DOCUMENTS
 1-800-522-6752

FOR APPLICATION
 TOOLING ASSISTANCE CENTER
 1-800-722-1111

FOR ORDER ENTRY
 1-800-526-5142

MAX RECOMMENDED OPERATING
 TEMPERATURE: 170°C MAX

VOLTAGE RATING:
 NOT APPLICABLE

WIRE CROSS SECTIONAL AREA RANGE:
 2.62-6.64mm² [5,180-13,100] CIR MILS
 STRANDED

DO NOT SCALE PRINT.
 UNLESS SPECIFIED
 DIMENSIONS IN MILLIMETERS
 TOLERANCES ON:
 2 PLG DEC ± .1
 3 PLG DEC ± .1
 ANGLES ± .5

MATERIAL:
 COPPER PER
 ASTM B-152
 ANNEALED

FINISH:
 TIN PLATE
 0.00254 [L. 000100] MIN
 THK PER MIL-T-10727

DR 2-9-93
 TA BRINKMAN

CHK 2-9-93
 DA PATTERSON

APPD 2-9-93
 DE MILLER

APPD 2-9-93
 JL NECKLEY

PRODUCT SPEC

APPLICATION SPEC

AMP
 AMP Incorporated
 Harrisburg, PA 17125-3608

TERMINAL, RING TONGUE,
 BUDGET

SIZE CAGE CODE DRAWING NO
 00779 31112

31112
 PART NO

CUSTOMER DRAWING